

COOLER DIMENSIONS A/AL

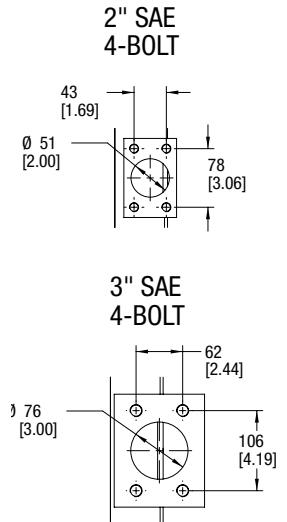
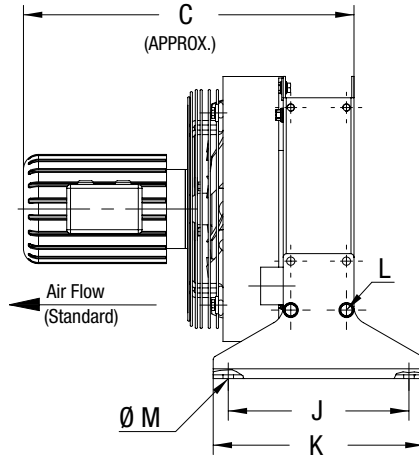
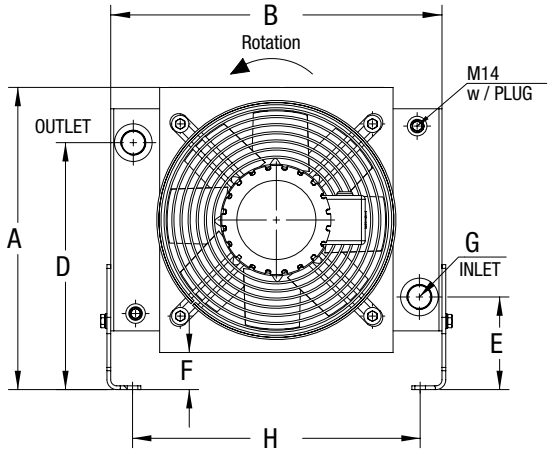

SELECTION PROCEDURES

The performance curves are based on the following:
 - 50 SUS Oil
 - 50 °F Entering Temperature Difference (ETD)

If your application conditions are different, use the following selection procedure:

STEP 1. DETERMINE THE HEAT LOAD

In most cases you can use 1/3 of the input horsepower.
 Example: 30 HP Power Unit = 10 HP Heat Load

STEP 2. DETERMINE THE ACTUAL ETD DESIRED

Entering OIL Temperature - Entering AIR Temperature = ETD
 The entering oil temperature is the highest desired oil temperature. The entering air temperature is the highest anticipated ambient air temperature, plus any pre-heating of the air prior to its entering the cooler.

STEP 3. CALCULATE THE ADJUSTED BTU/HR FOR SELECTION

$$\text{Horsepower} \times \frac{50}{\text{Desired ETD}} = \text{Horsepower For Use With Selection Chart}$$

STEP 4. SELECT THE MODEL FROM THE CURVES

Read up from the GPM to the required heat rejection. Select any model on, or above this point.

ORDERING INFORMATION

SERIES CODE: MODEL SIZE: MOTOR CODE: BYPASS DATA: CUSTOM FEATURE CODE:

--	--	--	--	--

SERIES: A = Standard, AL = Low Noise
 MODEL SIZE: Selected
 MOTOR CODE: 0 = No Motor, C = Core Only, 1 = Single Phase, 3 = Three Phase, 575 = 575 Volt
 BYPASS DATA: BPNV = Bypass No Valve, BP25 = 25PSI Internal Bypass, BP30 = 30PSI Internal Bypass, BP60 = 60PSI Internal Bypass, BP65 = 65PSI Internal Bypass.
 CUSTOM FEATURE CODE: B = Blowing Fan, AD = SAE to NPT Adaptors, H = Heresite Coating Core, F = Foam Filter

ORDER EXAMPLE: Heat Exchanger, 90 HP; Suction Fan, 3 Phase; 60PSI Internal Bypass A90-3-BP60

GLOBAL STANDARD **Cool-Line A**

STANDARD MODELS PERFORMANCE DATA (A-SERIES)

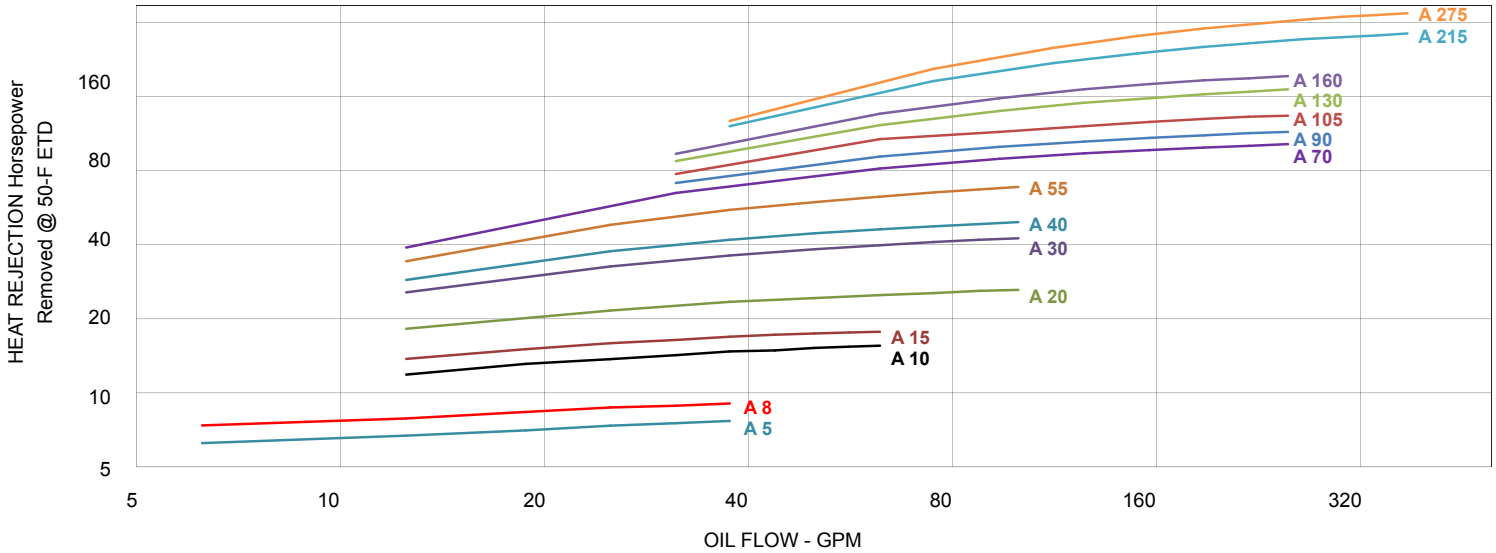

Specifications:

Maximum Working Pressure (A5 through A130)	377 PSI
Maximum Working Pressure (A160 through A275)	250 PSI
Maximum Working Temperature	250 °F

Materials:

Cooler	Aluminum
Shroud	Power Painted Steel
Fan Guard	Zinc Plated Steel
Fan Blade	Polypropylene Blades Aluminum Hub
Mounting Brackets	Powder Painted Steel

LOW NOISE MODELS PERFORMANCE DATA (AL-SERIES)

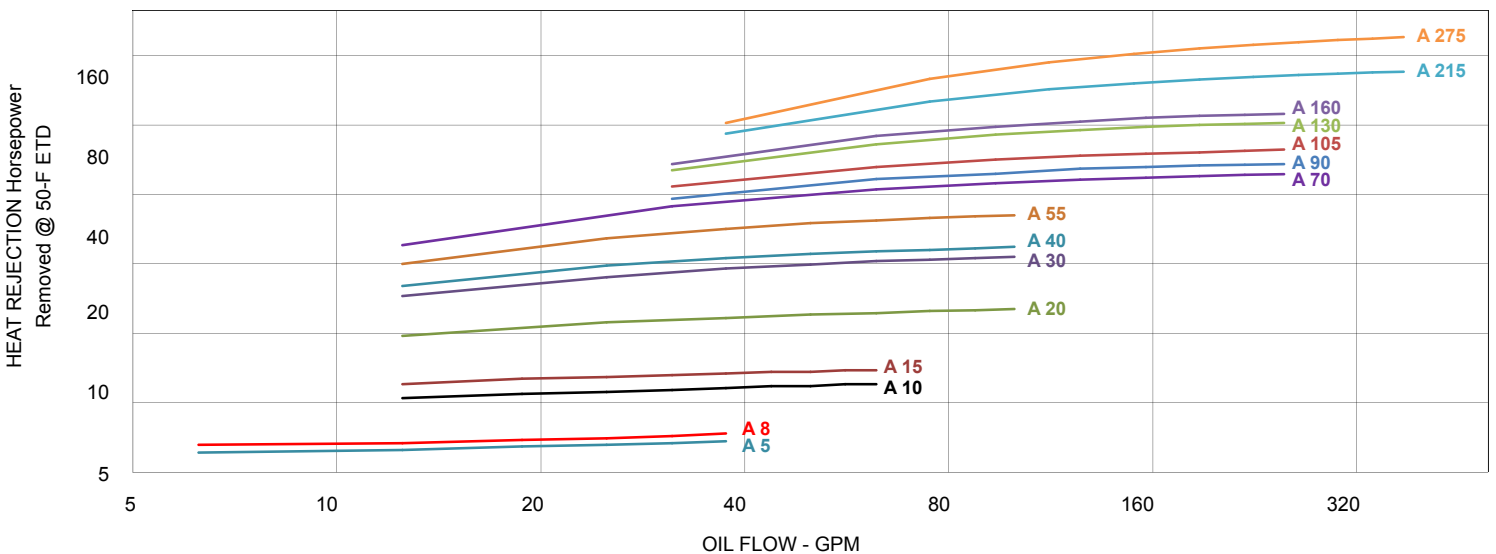

GLOBAL STANDARD Cool-Line A

A/AL SERIES TECHNICAL DATA

Model Size	HP RPM		Motor Frame		Voltage (3 Phase)	Hz	Full Load Amps 230 V		Approx. Noise Level (dB(A), 1m)		Working Pressure (psi)	Approx. Shipping Weight (lbs)
	A	AL	A	AL			A	AL	A	AL		
A/AL5	1/3 3425	1/4 1700	IEC 63	IEC 63	230/460 200/400	60 50	1.1	1	77	65	377	37
A/AL8	1/3 3425	1/4 1700	IEC 63	IEC 63	230/460 200/400	60 50	1.1	1	77	65	377	43
A/AL10	1/2 3425	1/3 1700	IEC 71	IEC 71	230/460 200/400	60 50	1.6	1.4	81	69	377	46
A/AL15	1/2 3425	1/3 1700	IEC 71	IEC 71	230/460 200/400	60 50	1.6	1.4	86	73	377	57
A/AL20	1/2 1700	1/3 1140	IEC 71	IEC 80	230/460 200/400	60 50	1.8	1.3	83	74	377	67
A/AL30	1 1725	1/2 1140	NEMA 56C	NEMA 56C	208-230/460	60*	3.8	2.4	86	75	377	137
A/AL40	1 1725	1/2 1140	NEMA 56C	NEMA 56C	208-230/460	60*	3.8	2.4	88	79	377	169
A/AL55	2 1725	3/4 1140	NEMA 56C	NEMA 56C	208-230/460	60*	6.2	3	92	83	377	205
A/AL70	2 1725	3/4 1140	NEMA 56C	NEMA 56C	208-230/460	60*	6.2	3	92	83	377	240
A/AL90	3 1725	1 1140	NEMA 56C	NEMA 56C	208-230/460	60*	8.6	4	94	85	377	277
A/AL105	3 1725	1 1140	NEMA 56C	NEMA 56C	208-230/460	60*	8.6	4	95	86	377	290
A/AL130	5 1740	1.5 1140	NEMA 184TC	NEMA 184TC	208-230/460	60*	13.2	5.7	97	88	377	414
A/AL160	7.5 1740	2 1140	NEMA 213TC	NEMA 213TC	208-230/460	60*	19.6	7.4	98	89	250	560
A/AL215	10 1740	5 1140	NEMA 215TC	NEMA 213TC	208-230/460	60*	26	17.6	101	92	250	640
A/AL275	10 1740	5 1140	NEMA 215TC	NEMA 213TC	208-230/460	60*	26	17.6	101	92	250	710

All data based at nominal speed

Electric Motors are TEFC and are not thermally protected.
 Actual rating may vary with motor brand. Check motor nameplate for actual rating.
 Motor RPM is reduced by 1/6 for 50 Hz service.
 * - 3 Phase motors available in 50 Hz.

A/AL SERIES DIMENSIONS

Model Size	A	B	C (Approx.)	D	E	F	G	H	J	K	L	M
A/AL5	13.74	13.78	12.56	11.38	4.37	1.97	#12 SAE 1 1/16-12 UN-2B	11.93	7.09	8.66	M6-1 X12MM Bolt (4 PL)	Ø 0.55
A/AL8	14.25	13.78	13.27	11.85	4.84	2.48	#12 SAE 1 1/16-12 UN-2B	11.93	7.09	8.66		Ø 0.55
A/AL10	15.91	15.75	14.50	12.54	4.87	1.50	#16 SAE 1 5/16-12 UN-2B	13.86	7.09	8.66	M8-1.25 X16MM Bolt (4 PL)	Ø 0.55
A/AL15	15.91	16.54	16.00	12.15	5.26	1.50	#16 SAE 1 5/16-12 UN-2B	14.65				Ø 0.55
A/AL20	19.60	21.65	15.50	16.24	4.87	1.50	#20 SAE 1 5/8-12 UN-2B	19.76				Ø 0.55
A/AL30	24.03	25.59	16.75	20.63	4.88	1.50	#20 SAE 1 5/8-12 UN-2B	23.70	10.24	11.81	M10-1.5 X20MM Bolt (8 PL)	Ø 0.55
A/AL40	24.03	26.38	18.00	17.68	7.84	1.50	#20 SAE 1 5/8-12 UN-2B	24.49				Ø 0.55
A/AL55	25.89	30.31	19.50	19.50	7.84	1.50	#20 SAE 1 5/8-12 UN-2B	28.32	10.24	11.81	M12-1.75 25MM Bolt (8 PL)	Ø 0.55
A/AL70	30.19	36.22	21.80	23.00	10.69	1.50	2" SAE 4-Bolt FLANGE	34.22	21.10	22.64		Ø 0.55
A/AL90	30.19	37.01	23.30	21.00	10.69	1.50		35.01	21.10	22.64	Ø 0.55	
A/AL105	33.26	38.98	23.40	24.07	10.69	1.50		36.98	21.10	22.64	Ø 0.55	
A/AL130	37.56	40.94	25.10	29.27	9.80	1.50	3" SAE 4-Bolt FLANGE	39.06	21.10	22.64	3/4-10 x 1.75 Bolt (8 PL)	Ø 0.55
A/AL160	38.40	43.62	29.50	31.27	9.94	2.00		40.17	14.72	17.72		Ø 0.75
A/AL215	46.96	49.49	30.80	36.03	12.73	2.00		48.22	15.70	18.70		Ø 0.75
A/AL275	59.76	53.68	30.70	43.62	17.56	2.00	50.34	17.67	20.67		Ø 0.75	

All dimensions in inch

GLOBAL STANDARD Cool-Line A

OIL-TO-AIR COOLING SYSTEMS WITH AC-MOTOR

PRODUCT INFORMATION

Cool Line is a standard line of products from the market leader in high performance aluminum cooling systems.

The Cool-Line type series consist of different models for mobile and stationary applications and are available through our global specialist dealer network. This line of products embraces all-purpose complete cooling systems that comply with European or American Standards, is suited for normal or rugged environmental operating conditions, and is powered by AC-, DC- or hydraulic-motor-driven fans and is also available with noise-optimized models.

FEATURES OF THE A/AL SERIES:

- High-Performance Aluminum cooling assemblies
- AC-motor powered fan
- The heat is transferred from the medium to be cooled to the ambient air
- Cooler can be universally used in hydraulic oil, transmission oil, engine oil, lubricating oil and coolant circuits
- For the cooling of mineral oil, synthetic oil, biological oil as well as of HFA, HFB, HFC and HFD liquids and water with at least 50 per cent of antifreeze and anticorrosive additives (other media available)
- Can be exposed to operating pressures of up to 26 bar or 17 bar, depending on model

BENEFITS:

- Highly flexible complete, ready-to-use cooling packages
- Compact and robust design, field-tested during many years of use in rugged real life conditions
- Largest and most comprehensive series of industrial coolers
- Best heat transfer results per given cooler size due to comprehensive research and development
- Highest quality due to professional engineering and in-house manufacturing
- Available from stock or at short notice
- As a standard, equipped with patented double-life hollow sections designed to increase cooler service life
- As a standard feature, available with louvered high-performance air fins or alternatively with non-louvered low fouling cooling air fins (AR-Series)
- Noise-optimized models available (low-noise series)

A/AL-Series FEATURES/BENEFITS

- New A optimized series coolers with louvered fin design provides the best HEAT TRANSFER per given cooler size in the industry.
- New A optimized series coolers offer increased performance with lower pressure drop than current same size AKG THERMAL SYSTEMS AC SERIES COOLERS.
- New AL low noise series coolers offer slower fan speeds for reduced noise level & lower fan HP requirements.
- New A/AL optimized series coolers have proprietary R & D designed, engineered and tested internal and external fins unique to THERMAL SYSTEM coolers.
- All A/AL series coolers are available with internal pressure BYPASS option.
- New A/AL optimized series coolers offer the largest, most comprehensive cooler size ranges with competitive pricing and deliveries from stock.

PATENTED FLEXIBLE HOLLOW PROFILE



Cool-Line uses patented hollow profiles to reduce local peak strains. This way the strength of heat exchangers is significantly increased and their service life time considerably prolonged.

HOLLOW PROFILE FEATURES :

- Reduced Strain:
Strength calculations show that when using hollow profiles maximum strain is reduced by a factor of 2
- Prolonged Service Life Time:
Extensive rig tests have shown that service life time increases by a factor ranging from 3 to 5

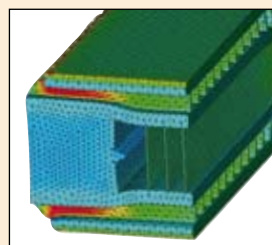

with standard profile

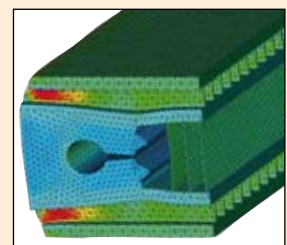

with hollow profile